

### Design:

- Door material: Glass
- Main color: Black ceramic glass
- Tinted door glass
- Full color display
- Display Touch TFT

### Features:

- 5 Air Flow™ system
- MultiSteam 360°
- Pure Steam system
- Stirrer technology
- Sous vide program
- Fully extendable telescopic guides on two levels
- Number of auto programmes : 160
- Heating functions :
  - Lower heater BIO
  - Upper heater
  - Lower and upper heater
  - Small infra heater
  - Large infra heater
  - Large infra heater with ventilation
  - Circular heater
  - Eco function
  - Lower heater and fan
  - Lower heater with fan BIO
  - Strong steam / Medium steam / Low steam
  - Steam baking
  - Defrost
  - WarmPlate
  - StayWarm
  - FastPreheat
  - STEPbake
  - AutoRoast
  - Microwave and grill
  - Microwave and hot air
  - Microwave

### Cleaning Features:

- Removable flat oven inner door glass surface
- AquaClean function
- Steam clean
- Descaling

### Safety Systems:

- Dynamic oven cooling plus – DC+
- Child lock
- SoftOpen and GentleClose door hinge
- Mechanic door safety bolt



### Technical information:

- Capacity: 50L
- Water tank capacity: 1.3L
- Maximum oven temperature: 230 °C
- Microwave power: 1000W
- Total connected load: 3000W
- Voltage (v): 220-240V
- Frequency: 50Hz

### Supplied accessories:

- Grill rack x 1
- Glass tray x 1
- Steam tray x 1
- Full width steam tray perforated x 1
- Shallow tray x 1
- 1/2width steam tray perforated x 1
- 1/3 width steam tray perforated x 1

### Appliance dimensions:

- 595W x 546D x 455H (mm)

### Built-in dimensions:

- 560-568W x min550D x min450H

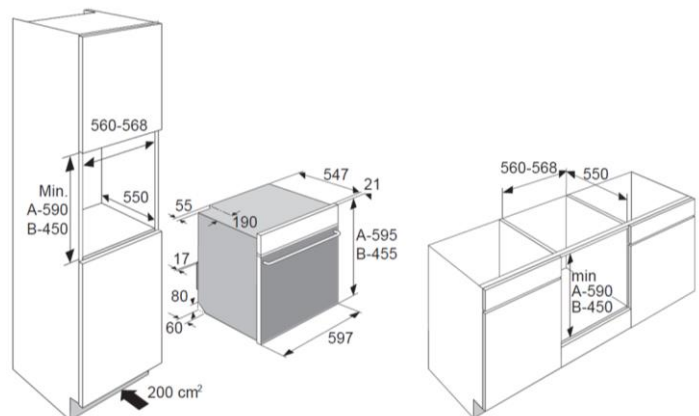

Sole Distributor of HKSAR & Macau:



A Great Eagle Trading Holdings Company

Made in Slovenia

The specifications are subject to change without prior notice. © Tiptech Co. Limited Nov 2021