

CBR4123N2M BUILT-IN REFRIGERATOR

Features:

- Electronic temperature control with LED display
- Interior LED light
- Flat and reversible door
- Crystal door balconies
- Super freeze
- Door alarm



Fridge section:

- Automatic defrosting system
- Tempered glass shelves
- Food care drawer

Freezer section:

- Manual defrosting system
- 4-star rating icebox

Technical information:

- Energy Efficiency Grade: Grade 1
- 1 compressor
- Net capacity:
 - Total: 183L
 - Fresh food: 169L
 - Freezer: 14L
- Energy consumption: 0.45kW/24hrs
- Climate class: N-ST
- Rated current: 0.45A
- Total input power: 80W
- Voltage / frequency: 220-240V / 50Hz
- Freezing capacity (24hrs): 2kg/24hr

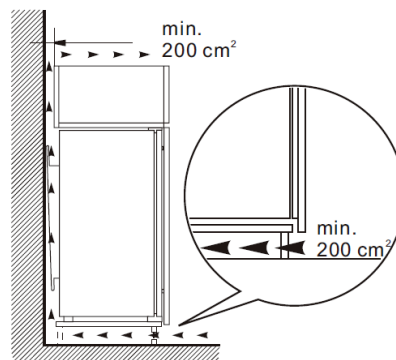
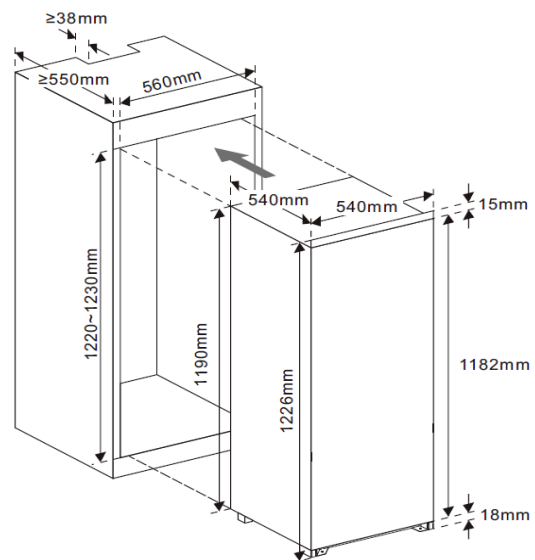

Appliances dimensions:

- Product dimensions (W x D x H): 540 x 540 x 1226 (mm)
- Built-in dimensions (W x D x H): 560 x 550 x 1220-1230 (mm)

Made in China