

**OBRB153 Freestanding Refrigerator**

**Features:**

- Mechanical control
- IonAir with DynamiCooling
- Crisp zone with humidity control
- FreshZone drawer
- Door bottle container
- LED strip by side
- Right door opening
- MultiBox container: 1
- Adjustable feet: 2

ENERGY LABEL	
能源標籤	
more efficient 更節能	Class 1
2	
3	
4	
5	
less efficient 較不節能	
Annual Energy Consumption (kWh/year) 全年耗電量 (kWh/年)	169
Fresh Food Volume (L) 鮮食保鮮室容積 (L)	220
Freezer Food Volume (L) 冷凍保鮮室容積 (L)	24
Refrigerating Appliances Refrigerator	Class
Model: SN153	QRN153BL
Reference Number / Year 參考編號 / 年	CU-ADR0001-2011 European Co. Limited 歐洲有限公司
機電工程師 EMSD	



OBRB153R

**Fridge section:**

- Auto defrost
- Interior ventilator
- 4 glass shelves (3 adjustable)
- Wire bottle rack
- Vegetable and cheese compartment

**Freezer section:**

- 1 door

**Technical information:**

- Energy Efficiency Grade: Grade 1
- 1 compressor
- Net capacity:
  - Total: 250 L
  - Fridge: 225 L
  - Freezer: 25 L
- Annual energy consumption: 161kWh
- Energy consumption: 0.441kW/24hrs
- Climatic class: SN, N, ST, T
- Connected rating: 80 W
- Noise level: 40 dB(A) re 1 pW
- Current: 10 A
- Voltage: 220-240 V
- Frequency: 50 Hz
- Freezing capacity (24hrs): 2kg/24hr
- Safe storage period if power failure: 17hrs
- 2 temperature zones
- Temperature range: -24°C - +10°C
- Ambient temperature: 10°C - 43°C
- Net weight: 58.5kg



OBRB153BK



OBRB153BL

**Appliances dimensions:**

- 1540H x 600W x 669Dmm

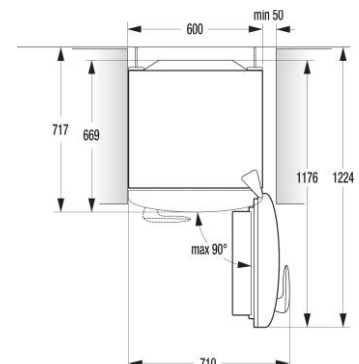

Made in Serbia

The specifications are subject to change without prior notice. © Toptech Co. Limited