

BCM547S12X Built-in compact combi-microwave oven

Design:

- Black glass with stainless steel side trims
- HomeMade² cavity design
- TouchFree Inox
- IconTouch electronic control



Features:

- Inverter & Stirrer technologies
- MultiFlow 360°
- 8 oven + 2 microwave functions:
 - Microwave
 - Microwave with hot air
 - Conventional heating (upper heater + bottom heater)
 - Grill
 - Fan grill
 - 3D hot air
 - Eco hot air
 - Bottom heater with hot fan
 - FastPreheat
 - Defrost
- 5 automatic defrost programmes
- Start delay, max. 10hrs
- Minute minder, max. 24hrs
- Adjustable feet

Cleaning features :

- AquaClean
- SilverMatte enamel interior
- Full glass inner door, removable

Safety systems:

- DynamiCooling System +
- Child lock
- Microwave Cool Door, 3 glass layers

Technical information:

- 50L usable volume
- 250°C max. temperature
- Microwave output: max. 1000W
- Grill output: max. 2200W
- Total connected load: 3000W (20A)

Supplied accessories:

- 1 glass baking tray
- 1 shallow baking tray with SilverMatte
- 1 oven grid

Appliance dimensions:

- 455H x 595W x 546D

Niche dimensions:

- 450-455H x 560W x 550D

Made in Slovenia

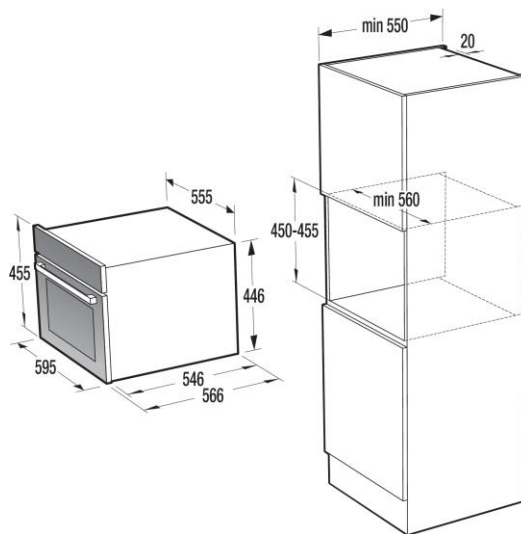

*Socket location should be accessible. Position behind the appliances is not recommended.

The specifications are subject to change without prior notice. © Toptech Co. Limited Sep 2017