

BCM547ST Built-in compact combi-microwave oven

Design

- + Silver grey glass front
- + Brushed stainless steel handle
- + HomeMade² design cavity
- + IconTouch electronic control



Features

- + Inverter & Stirrer technologies
- + 8 oven functions + 2 microwave functions :
 - + Microwave
 - + Microwave + hot air
 - + Conventional heating (upper heater + bottom heater)
 - + Grill
 - + Fan grill
 - + Bottom heater with hot fan
 - + 3D Hot air
 - + FastPreheat
 - + Eco function
 - + Defrost
- + 5 automatic defrost programmes
- + Start delay
- + Minute minder
- + Adjustable feet

Cleaning features

- + AquaClean
- + SilverMatte enamel cavity

Safety systems

- + DynamiCooling system +
- + Child lock
- + Triple glazed door with protective grid

Technical information

- + 50L usable volume
- + 250°C max. temperature
- + Microwave output: max. 1000W
- + Grill output: max. 2200W
- + Total connected load: 3000W

Supplied accessories

- + 1 glass baking tray
- + 1 shallow baking tray
- + 1 oven grid

Appliance dimensions

- + 455H x 595W x 546D

Niche dimensions

- + 450-455H x 560W x 550D

Made in Slovenia

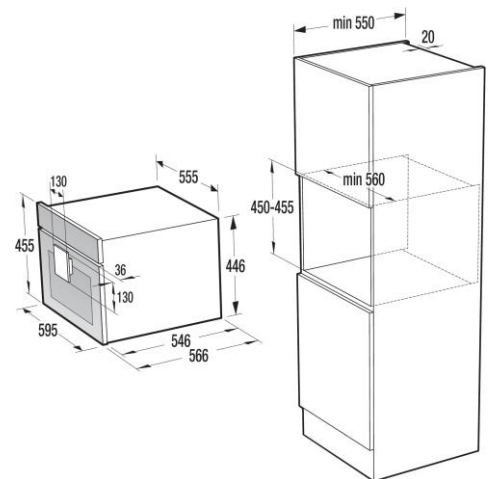

The specifications are subject to change without prior notice. © Toptech Co. Limited Sept 2017.