

CMA9200UX Built-in coffee machine

Design:

- Black glass with stainless steel side trims
- Touch control with LCD display
- Separate milk container and water tank
- Separate container for coffee bean and pre-ground coffee
- Height adjustable coffee dispenser



Features:

- Types of beverages:
 - Espresso
 - Cappuccino
 - Caffè Latte
 - Coffee
 - Hot water
 - Milk froth
- Automatic cappuccino function
- Number of cups at the same time : 2
- Adjustable coffee flavour intensity: 5 flavours
- Adjustable hot water & milk quantity
- Number of different shots of espresso coffee: 3
- Adjustable coffee temperature : 3
- Adjustable grind level: 9 levels
- One touch for rinse cycle
- Minute minder

Cleaning features :

- Descaling
- One touch for milk container's nozzle cleaning

Technical information :

- 2 heating elements
- 15 bar pump pressure
- Capacity :
 - Water tank : 1.8L
 - Milk container : 1L
- 200g coffee bean container capacity
- Total connected load: 1350W (13A)

Supplied accessories:

- Measuring spoon
- Descaling tablets

Appliance dimensions :

- 455H x 595W x 381D

Built-in dimensions :

- 450H x 560W x 550D

Made in Italy

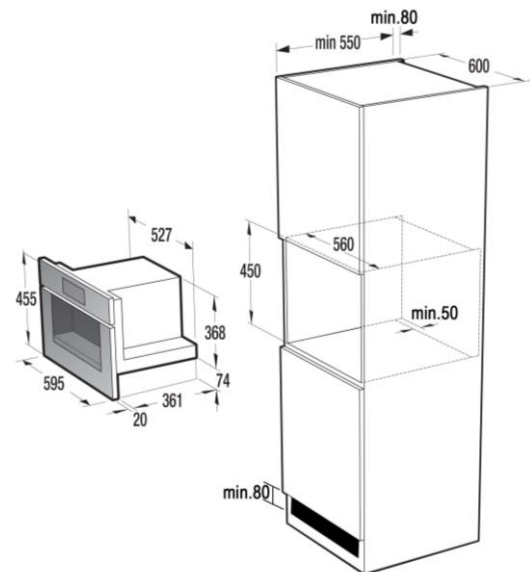

The specifications are subject to change without prior notice. © Toptech Co. Limited