

RBI4122E1 built-in refrigerator (1225mm)

Features:

- Mechanical control
- Reversible hinge door
- Crisp zone with humidity control
- Door bottle container
- LED strip by side
- Sliding door hinge
- Multi adjust shelves
- 1 independent cooling system

Fridge section:

- Auto defrost
- 4 glass shelves (3 adjustable)
- Vegetable compartment
- 1 egg rack

Freezer section:

- Manual defrost
- 1 ice tray

Technical information:

- Energy Efficiency Grade: Grade 1
- 1 compressor
- Net capacity:
 - Total: 180 L
 - Fridge: 165 L
 - Freezer: 15 L
- Annual energy consumption: 138kWh
- Energy consumption: 0.3781kW/24hrs
- Energy efficiency class: A++
- Climatic class: ST
- Voltage: 220-240 V
- Frequency: 50 Hz
- Freezing capacity (24hrs): 2kg/24hr
- Storage period if power failure: 14hrs
- 2 temperature zones

Appliances dimensions:

- 1225H x 540W x 545Dmm

Built-in dimesions :

- 1228-1233H x 560-570W x 560Dmm

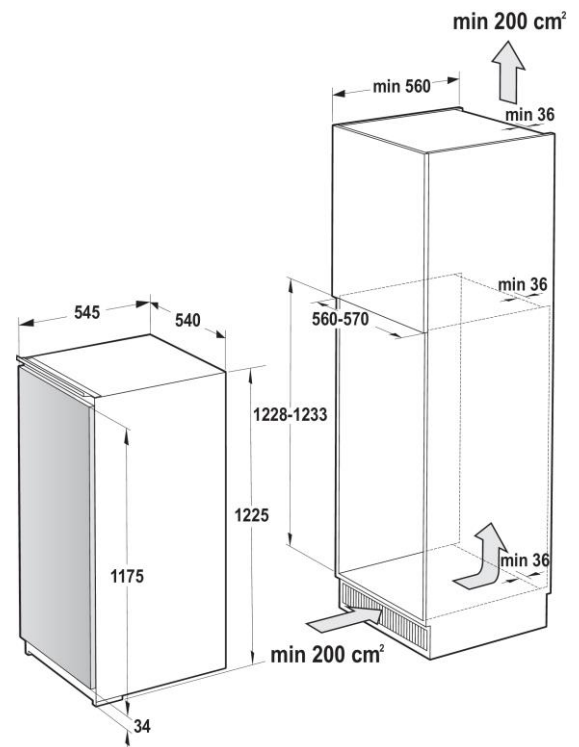

Made in Serbia

The specifications are subject to change without prior notice. © TopTech Co. Limited