

WHT943A2XBG 900mm wall-mounted cooker hood

Design:

- Black glass front panel
- SliderTouch control
- TouchFree Inox



Features:

- 3 speed levels
- 2 PowerBoost
- AdaptTech : Automatic fan operation
- Constant ventilation ReFresh
- Dimmer function
- Grease filter indicator
- Exhaust and re-circulate air operation

Technical information:

- EU Energy efficiency class: A
- EU Fluid dynamic efficiency class: A
- EU Grease filtering efficiency class: B
- EU Lighting efficiency class: A
- Max. airflow by extraction operation: 565m³/hr
- Airflow at boost position (PowerBoost 2): 775m³/hr
- 2x 3W LED diodes
- Total connected load: 284W (16A)

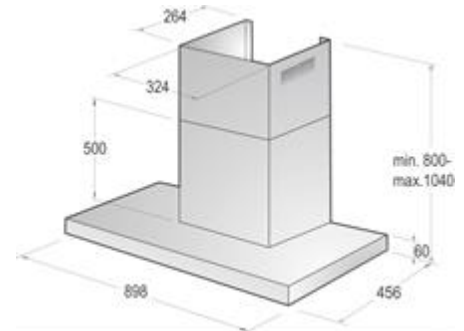

Appliance dimensions:

- 800-1040H x 898W x 456D

Made in Poland

The specifications are subject to change without prior notice. © Toptech Co. Limited May 2020